

Heat recovery ventilator unit with counterflow core

HRU-SlimAIR-NA

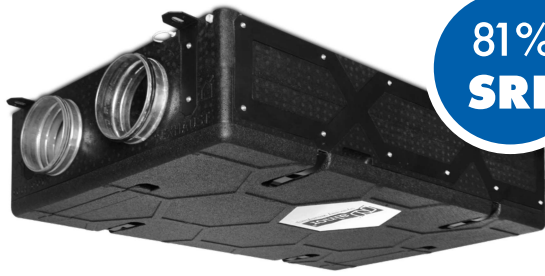

81%
SRE



Description

Heat recovery ventilation unit HRU-SlimAIR-NA-250 is a modern device with 153 CFM (72 L/s) air flow at 0.4" w.g. (100 P.a) external static pressure. Unit is made from cutting edge materials - PET counterflow core with high temperature recovery efficiency and EPP self supporting casing which has good acoustic and thermal isolation properties. HRU-SlimAIR-NA air handling units optionally can be equipped with two different defrost strategies. Recirculation unit, which task is to recover heat from extracting areas. Second option is electrical pre-heater which also prevents the heat exchanger from freezing. The device operation is controlled by an advanced PCB with wired control panel. In addition, the HRU-SlimAIR-NA can be connected to the Internet and controlled via a mobile application or website.

Features:

- HRV Heat Recovery Ventilator with PET counterflow core
- 153 CFM supply air @ 0.4" w.g.
- SRE 81 %
- Top ports 160mm (6 1/4") with rubber seals
- Easy accessible MERV 7 filters
- EPP insulated casing
- Weight: 56.2 lbs (25.5 kg) including core
- Centrifugal fans with backward curved blades with low energy consumption EC motors



Dimensions

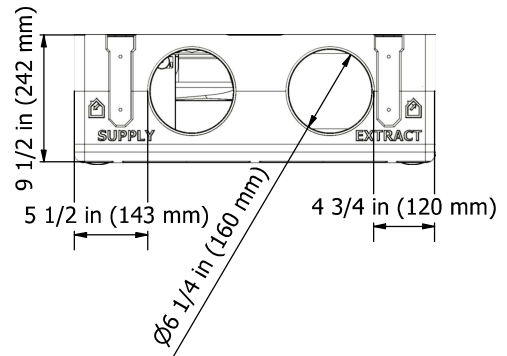
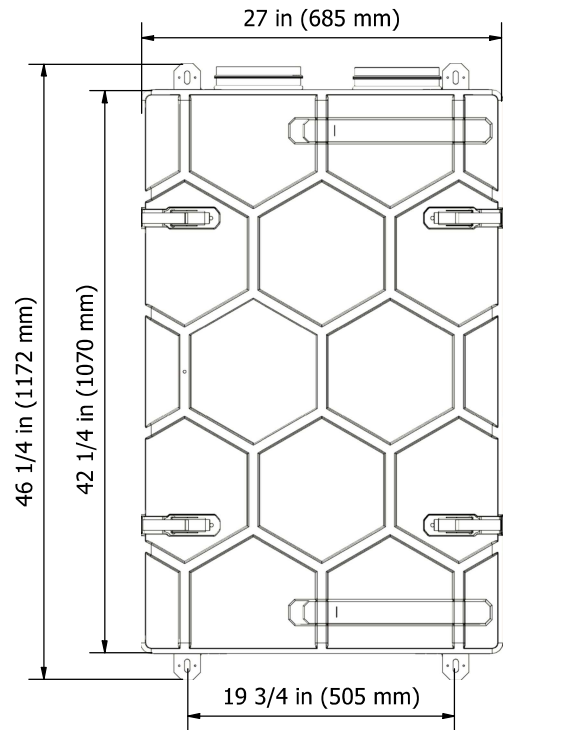

Electrical requirement

120 VAC, 60Hz, 1 Phase
Cord Set: Type B 70 3/4 in (1800 mm) with ground

Heat recovery ventilator unit with counterflow core

HRU-SlimAIR-NA



Air flow

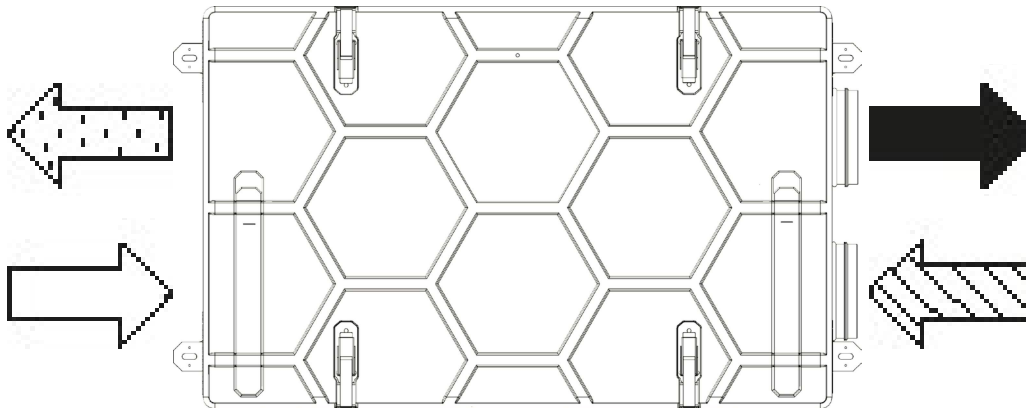
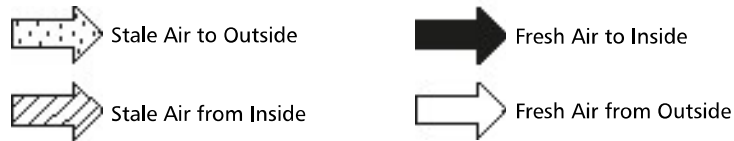

Controller

Ventilation units can be controlled in several ways:

- The HRQ-BUT-PG15 panel is should be a not an wired option with limited manual control options of the ventilation unit with Physical buttons allows you to choose between 4 speeds (PAUSE, LOW, MEDIUM, HOME). It also allows you to pick actual mode (MANUAL, SCHEDULE), turn (ON/OFF) AUTO mode or turn (ON/OFF) UNIT. The panel also has wireless control of unit (built in Bluetooth and WI-FI module) via APP for Android, IOS and browser.
- Cloud service for Android, iOS and via a browser (requires panel HRQ-BUT-PG15)

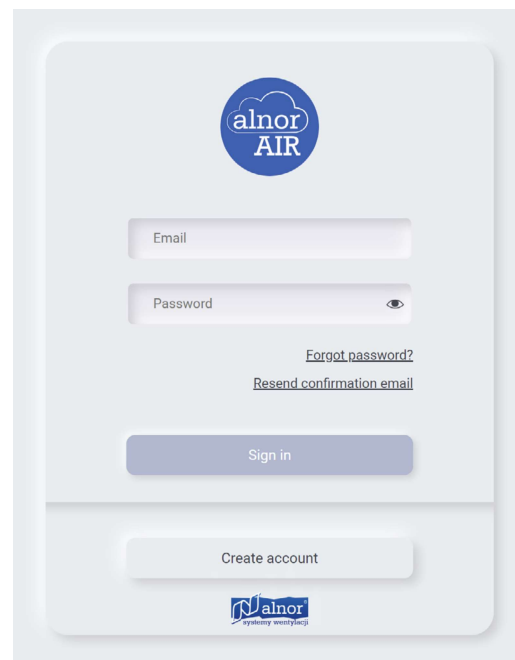

Heat recovery ventilator unit with counterflow core

HRU-SlimAIR-NA



- Application**
 The panel is connected to the local network via WI-FI. Communication with the device is wireless. On-line control is possible after installing the application on Andriod and iOS or via a browser on a computer. The application graphically illustrates the operation of the device, allows you to choose between 4 speeds (PAUSE, LOW, MEDIUM, HOME), time programs (EXIT, PARTY, AIRING), program the calendar and read additional operating parameters such as temperatures, current fan speeds or RH level. It also allows you to configure ventilation speeds (according to user preferences).

Note!
 Controller is not included in the kit. During purchase, choose the controller that is right for you.

Performance

- SRE up to 81.3 %
- Hi-tech modern casing made of Expanded Polypropylene – EPP
- High mechanical resistance
- High thermal and acoustic insulation
- Performance tested according to CSA C439-18 standard
- Wall mounting racks and feet included
- Replaceable duct connections
- Wireless control through mobile application or web service
- Wired function controller
- Light weight construction – only 25.5 kg!
- POLISH product

Design

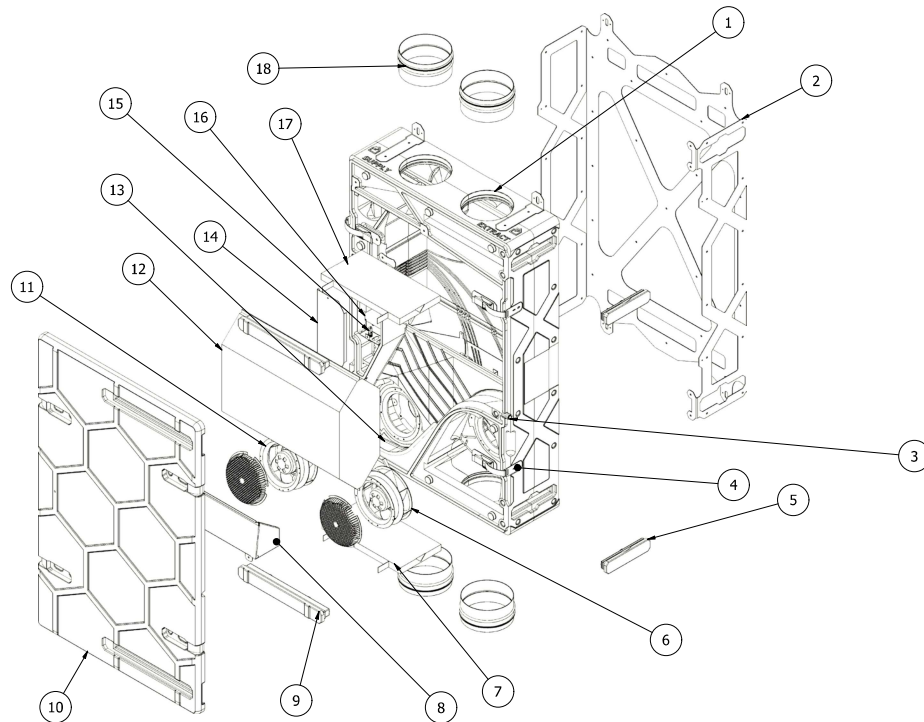

1. HRU housing	10. Front cover
2. Handling chassis	11. Extract fan
3. Side condensation drain	12. Core
4. Clamp	13. Lower condensation drain
5. Side filter cover	14. Control circuit metal cover
6. Supply fan	15. Main fuse
7. Supply filter	16. Control drcuit board
8. Condensation drip tray	17. Extract filter
9. Filter cover	18. NSL connector

Heat recovery ventilator unit with counterflow core

HRU-SlimAIR-NA



Defrosting system

There're 3 available defrosting options:

1. Recirculation
2. Preheater with unbalance
3. Unbalance

1 Recirculation

Heat recovery unit has the possibility to connect the Alnor Recirculation System. The function allows you to control the valve that redirects air from the exhaust to the unit's intake (depending on outdoor temperature conditions).

Recirculation operates between - 25°C to -3°C.

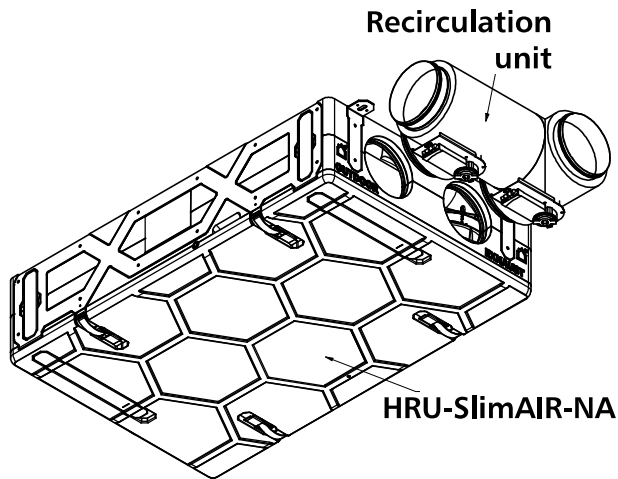

Available combinatons



HRQ-SlimAIR-NA-250-REC

HRU-SlimAIR-NA-250

OFF

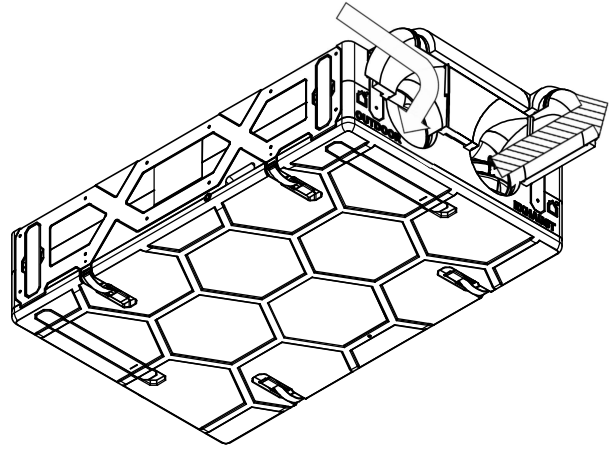

ON

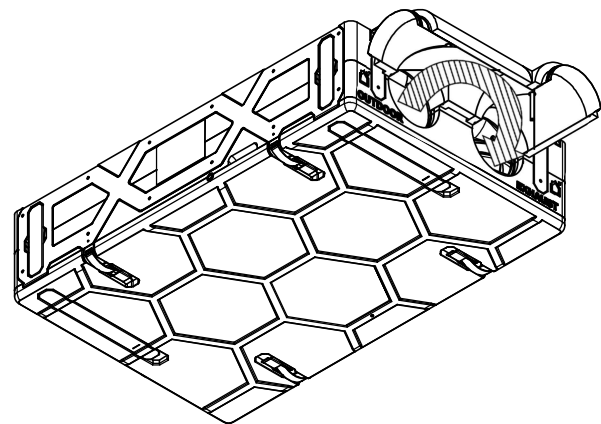

Heat recovery ventilator unit with counterflow core

HRU-SlimAIR-NA



2 Preheater



HRQ-HDE-CO1-P-160-2,5-120V round duct electric heater is designed for ventilation systems with residential air handling unit to use as pre-heaters - serve as additional (optional) frost protection for the core and therefore allow the unit to work in a balanced way even during heavy winter conditions. The casing is made from galvanised steel sheet, the heating elements are made from stainless steel. Heaters are equipped in a two-stage overheat protection. The first thermostat is an automatic-reset temperature limiter set to trip at +60°C. The other thermostat is a manual temperature limiter set to trip at +90°C (once tripped, this device needs to be reset by hand). Ducted electric heaters feature EPDM gaskets at the male connection ends and a 3m long power cord for external power and a dedicated steering plug for HRVs. Detailed installation instructions are described in the manual.

Preheater operates below -3°C.

Connection diagram

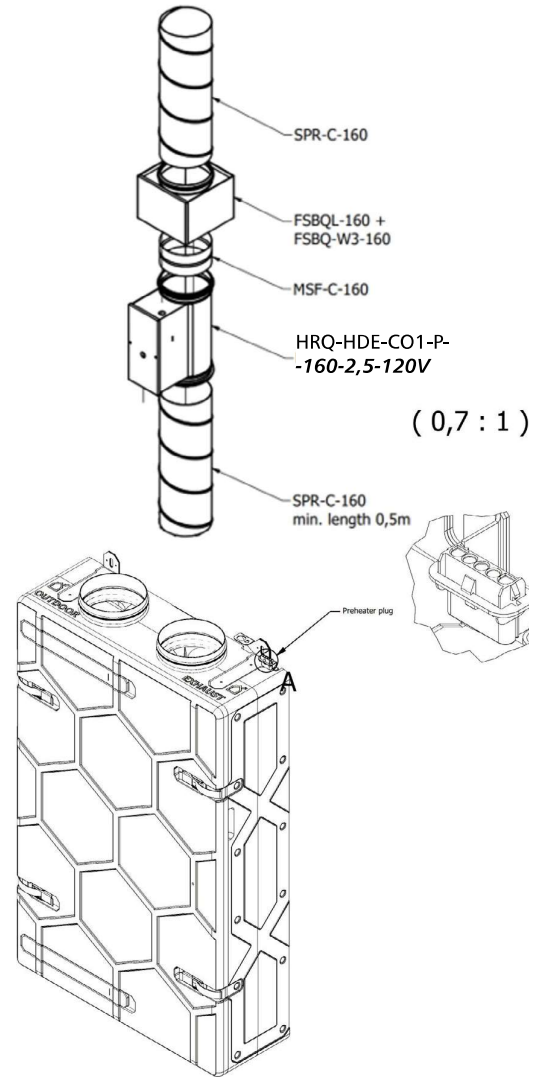

Available combinatons

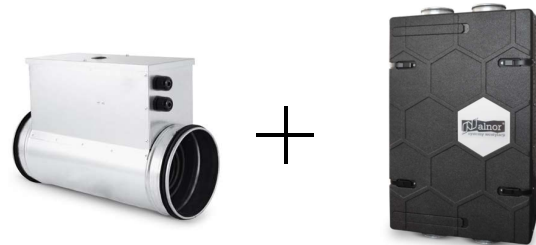

HRQ-HDE-CO1-P-160-2,5-120V

HRU-SlimAIR-NA-250

HRU-SlimAIR-NA



3 Fan unbalance

Frost protection is achieved by reducing the supply fan's speed to the minimum level of the fan. The whole process goes gradually, depending on the outdoor temperature drop. When the outdoor temperature continues to decrease and the fan has reached the set minimum revolutions.

Unbalance works within -3°C to +1°C.

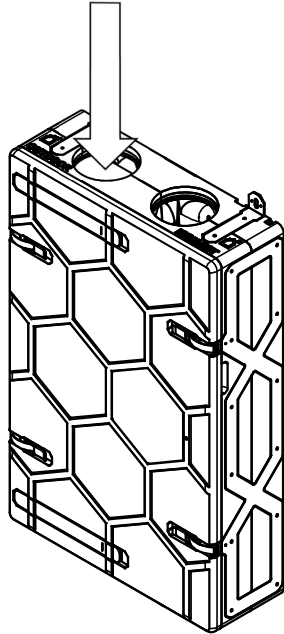

External Static Pressure	Net Supply Air Flow			Gross Air Flow				Power
				Supply		Exhaust		
Pa	In. W. G.	L/s	CFM	L/s	SCFM	L/s	SCFM	Watts
25	0,1	85	180	86	182	82	174	112
50	0,2	81	172	81	172	79	167	108
75	0,3	76	161	76	161	75	159	110
100	0,4	72	153	72	153	71	150	105
125	0,5	67	142	67	142	67	142	104
150	0,6	63	133	63	133	63	133	102
175	0,7	58	123	58	123	59	125	100
200	0,8	53	112	53	112	54	114	98
225	0,9	47	100	47	100	50	106	96
250	1,0	41	87	41	87	46	97	93
300	1,2	26	55	26	55	38	81	85

Ventilation performance

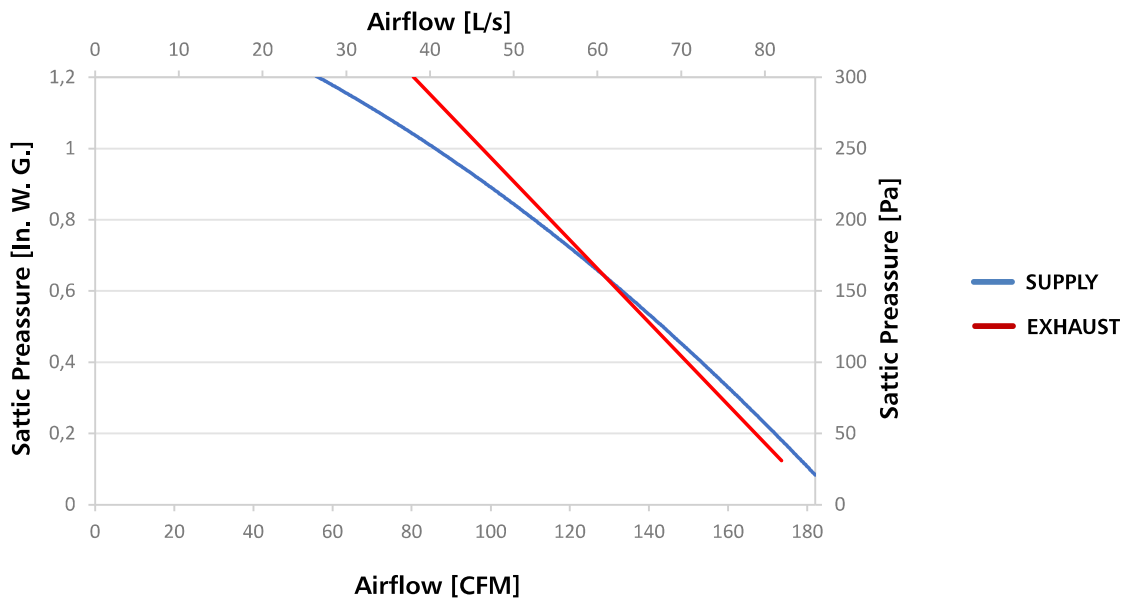

Heat recovery ventilator unit with counterflow core

HRU-SlimAIR-NA



Energy performance

Supply Temperature		Net Outdoor Air Flow		Power Consumed (Watts)	Sensible Recovery Efficiency	Adjusted Sensible Recovery Efficiency	Apparent Sensible Effectiveness	Latent Recovery/ Moisture Trans
°C	°F	L/s	CFM					
Heating								
0	32	23	49	19	76	79	89	0,00
0	32	31	66	25	81	84	89	0,00
0	32	50	106	49	80	83	86	0,00
-25	.13	42	89	92	67	69	120	0,08

Filters

- Filter HRQ-SlimAIR-FILT-G4 (standard)**

G4 pleated panel filters creates a larger media surface area for air filtration and ensures lower pressure drops. Filters are classified as in the ISO Coarse 70% according to ISO 16890 standards, which is an equivalent to MERV 7.

Code	Filter class	Dimensions [mm]
HRQ-SlimAIR-FILT-G4	ISO Coarse 70% (MERV 7)	423x223x23



- Filter HRQ-SlimAIR-FILT-F7 (optional)**

F7 is classified as a fine filter according to EN 779:2012 norm and as ePM1 55% in accordance with new standard ISO 16890, which is an equivalent to MERV 13.

Code	Filter class	Dimensions [mm]
HRQ-SlimAIR-FILT-F7	ISO ePM1 55% (MERV 13)	423x223x25

